

DBL024-05XX

Electronically commutated sensorless motor, slotless stator design, Hollow shaft

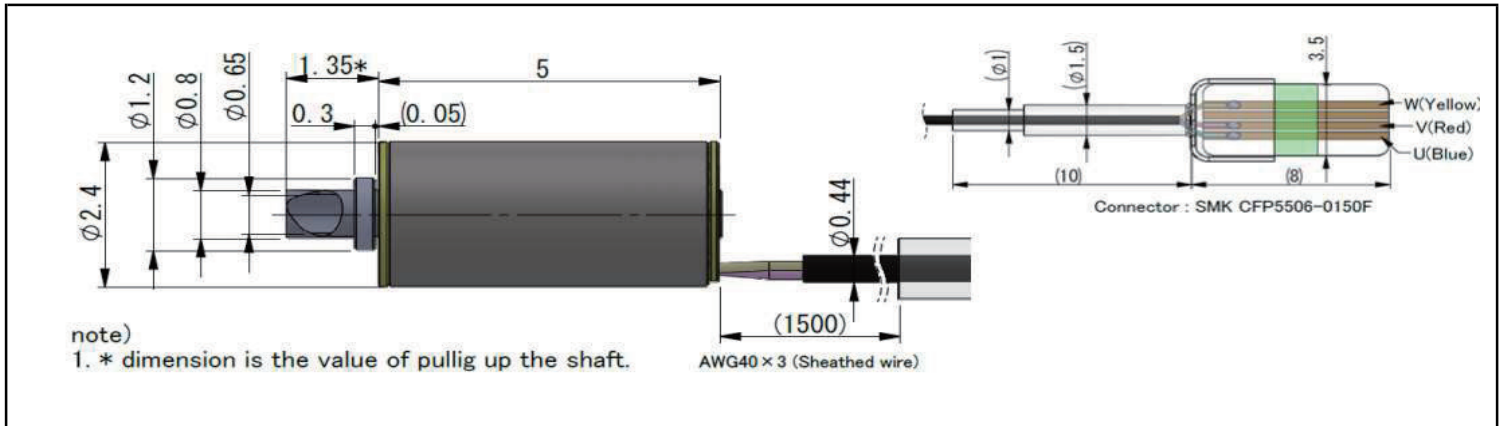

Specification	DBL024-05XX		Notes
1 Rated voltage	4.0 V		
2 Terminal resistance	89 Ω	$\pm 10\%$	at (25 °C \pm 5°C) Including lead wire resistance*
3 Stall current	44 mA	$\pm 10\%$	Calculated value (1 / 2)
4 Back-EMF constant	0.024 mV/rpm	Min.	
5 Torque constant	0.23 mNm/A	Min.	
6 Stall torque	0.010 mNm	Min.	Calculated value (3* 5)
7 Operating Speed	100~6000 rpm		Drive Circuit ; SOD12ST
8 Total length	5.0 mm		
9 Direction of rotation	CW/CCW		
10 Insulation resistance	OL		Between Housing and Terminal *lead wire length =1500mm